

Hydrologic Cycle & Elements

Conservation of Mass Principle Handout:

(See in course website: Supporting Handouts)

CWR 5305 - Surface Hydrology

FIU Department of Civil & Environmental Engineering

Professor Fuentes

Control Volume Approach: Hydrosystems

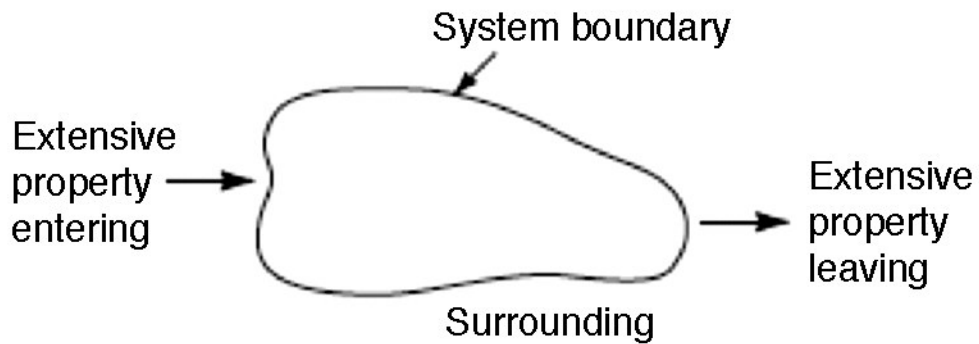

(a)

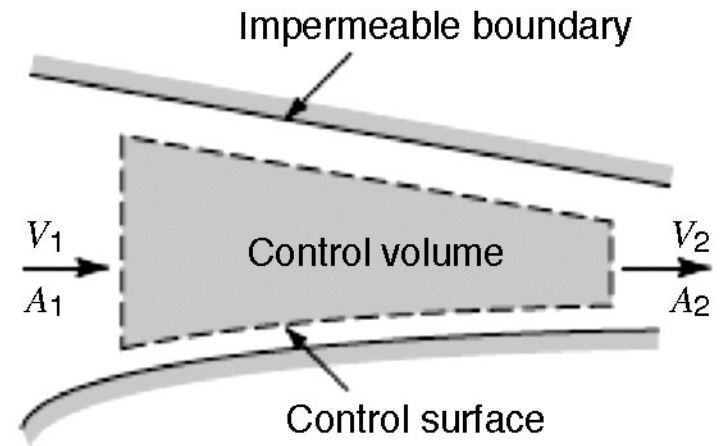

(b)

Figure 1.1.6
© John Wiley & Sons, Inc. All rights reserved.

Drainage Basins, Watersheds, Catchments or Drainage Areas

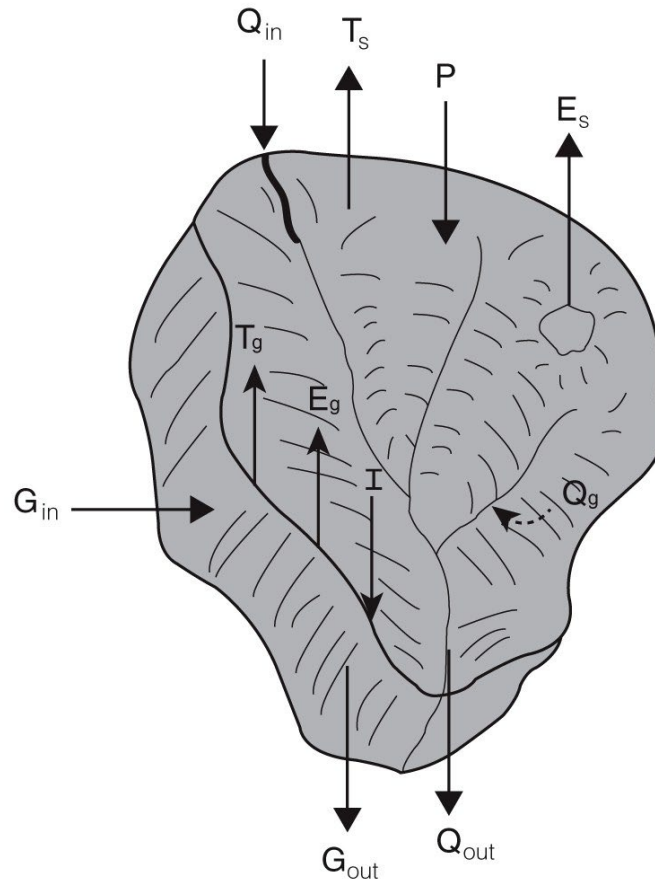

Figure 7.1.11
© John Wiley & Sons, Inc. All rights reserved.

Sketch of a River Basin

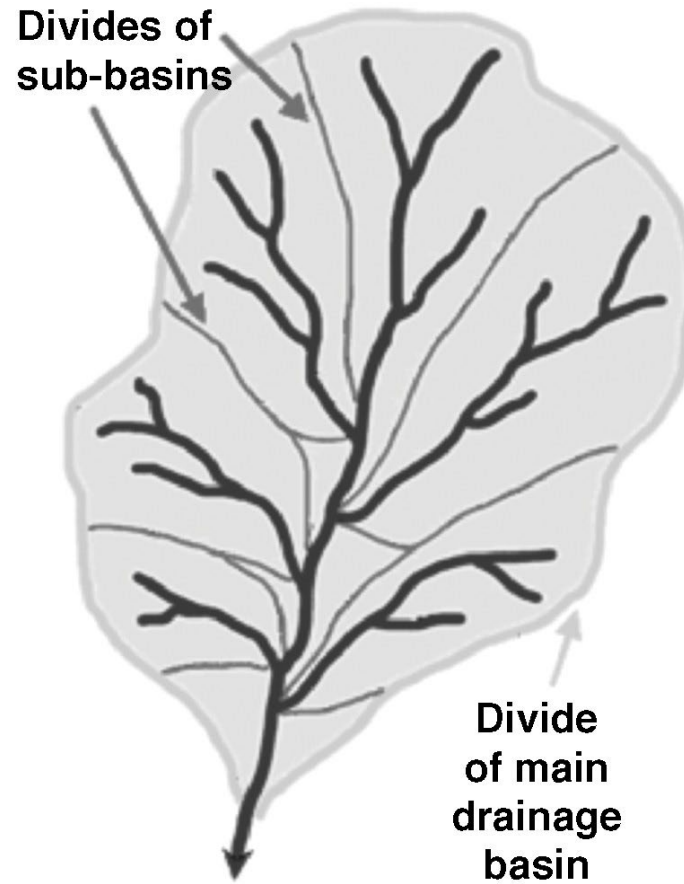
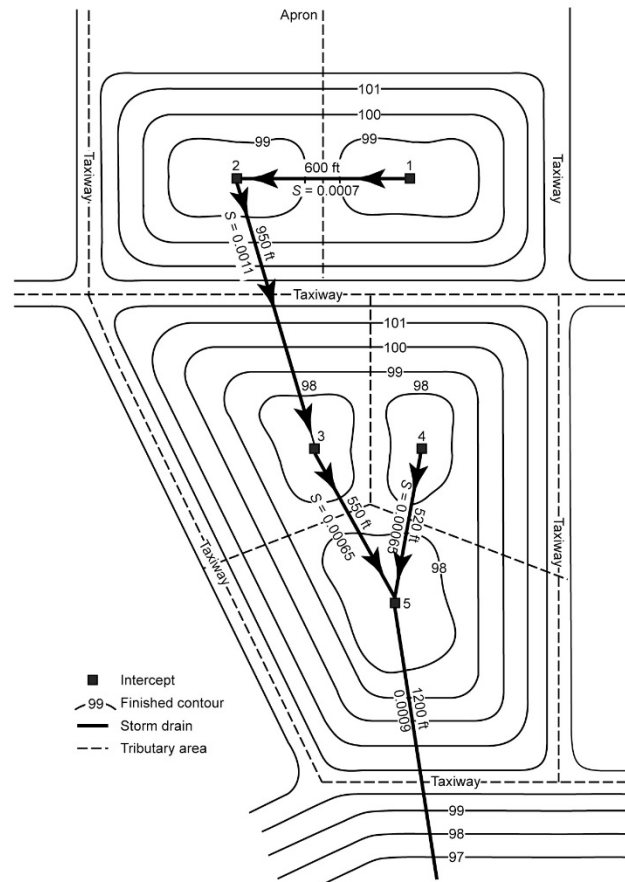

Figure 7.1.1
© John Wiley & Sons, Inc. All rights reserved.

Airport Drainage Area: Example

Figure 17.10 Section of an airport.



Conservation of Mass Principle: Water Balance (or Budget) Equation(s)

- A general equation is Eq. 2.1:

$$P + Q_{SI} + Q_{GI} - E - Q_{SO} - Q_{GO} - \Delta s - n = 0, \text{ for a } \Delta T \text{ (1 week, 1 year, etc.)}$$

When either volumes, flow rates or mean depths for the ΔT are used

- For water bodies, short-duration (Eq. 2.2):

$$P + Q_{in} - E - Q_o - \Delta s = 0$$

If inflow and outflow terms in Eq. 2.1 are combined and n is “nil”

- For large basins for Long Duration (Eq. 2.3):

$$P - E - Q_o = 0$$

If surface inflow, groundwater inflow and outflow terms in Eq. 2.1 and n are ignored or “nil”

- For direct runoff in a basin, over the ground surface, during a storm (Eqs. 2.4, and 2.5):

$$P - E - I - S_D - R = 0 \text{ (Eq. 2.4)}$$

If evaporation, interception and depression storage are much smaller than infiltration, Eq. 2.4 becomes,

$$R = P - I \text{ (Eq. 2.5)}$$

Discrepancy Term & Errors

Table 2.1 Percent Errors in Hydrologic Components by Commonly Used Methodologies

	Percent Error	
	Annual Estimate	Monthly Estimate
1. Precipitation		
Gage observation	2	2
Gage placement (height)	5	5
No windshield		20
Areal averaging	10	15
Gage density	13	20
2. Streamflow		
Current-meter measurement	5	5
Stage-discharge relationship	20	30
Channel bias	5	5
Regionalization of discharge	70	
3. Evaporation		
Energy budget	10	
Class A pan	10	10
Pan to lake coefficient	15	50
Areal averaging	15	15

Source: Based on Winter (1981).

Hydrologic Cycle

Precipitation

CWR 3540: Water Resources Engineering
FIU Department of Civil & Environmental Engineering
Professor Fuentes

Standard Rain Gage – Non-recording



Figure 12.1.6
Courtesy of the National Oceanic and Atmospheric Agency

Weighing Bucket Rain Gage - Recording

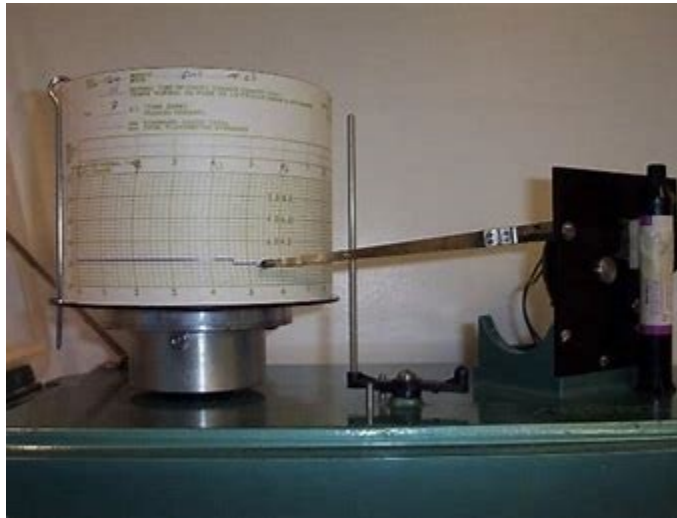

Tipping Bucket Rain Gage (Exterior)



Figure 12.1.8b
www.wikipedia.com

Example Rain Record and Hyetograph

TABLE 4.1 Hourly Precipitation Record for Washington, D.C., for September 1983

Date	Hourly Precipitation (Water Equivalent in Inches)												Date													
	A.M. Hour Ending At						P.M. Hour Ending At																			
	1	2	3	4	5	6	7	8	9	10	11	12	1	2	3	4	5	6	7	8	9	10	11	12		
1																									1	
2																										2
3																										3
4																										4
5																										5
6																										6
7																										7
8																										8
9																										9
10																										10
11																										11
12																										12
13	0.06	T																								13
14																										14
15																										15
16																										16
17																										17
18																										18
19																										19
20																										20
21																										21
22																										22
23																										23
24																										24
25																										25
26																										26
27																										27
28																										28
29																										29
30																										30

Note: T indicates trace amount.

MAXIMUM SHORT-DURATION PRECIPITATION												
TIME PERIOD (MINUTES)	5	10	15	20	30	45	60	80	100	120	150	180
PRECIPITATION (INCHES)	0.12	0.18	0.21	0.26	0.35	0.40	0.45	0.50	0.58	0.63	0.75	0.81
ENDED: DATE	13	13	13	13	13	13	13	13	13	13	21	21
ENDED: TIME	1053	1058	1058	1100	1110	1115	1122	1142	1208	1222	1748	1818

THE PRECIPITATION AMOUNTS FOR THE INDICATED TIME INTERVALS MAY OCCUR AT ANY TIME DURING THE MONTH. THE TIME INDICATED IS THE ENDING TIME OF THE INTERVAL. DATE AND TIME ARE NOT ENTERED FOR TRACE AMOUNTS.

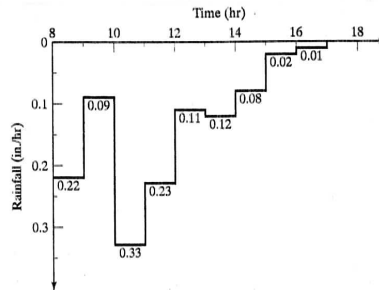

Figure 4.1 Hourly precipitation in Washington, D.C., on September 13, 1983.

SOURCE: McCuen, D.H., 3rd Edition, 2005
(Pearson, Prentice-Hall)

Rainfall Hyetographs

- *Hyetograph:*

Plots of rainfall depth or intensity as function of time

Examples of Hyetographs:

Depth or intensity versus time
Cumulative (or “rainfall mass curve”)

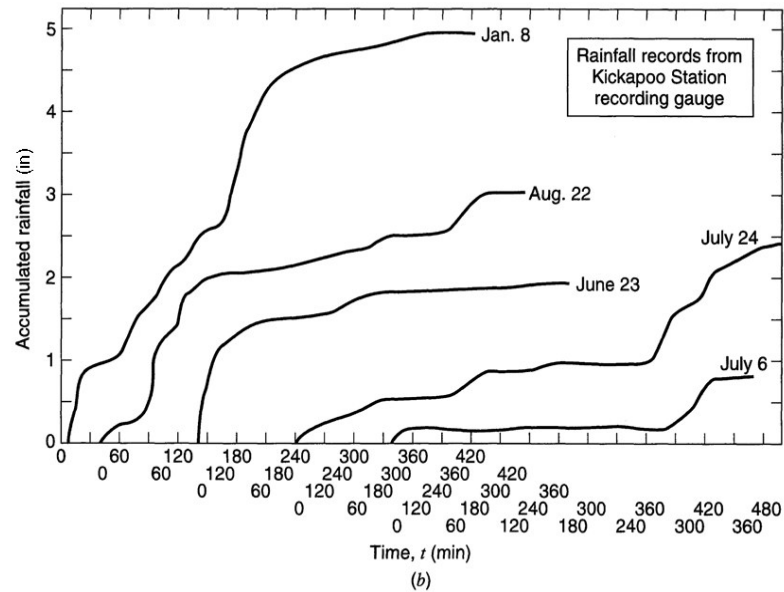
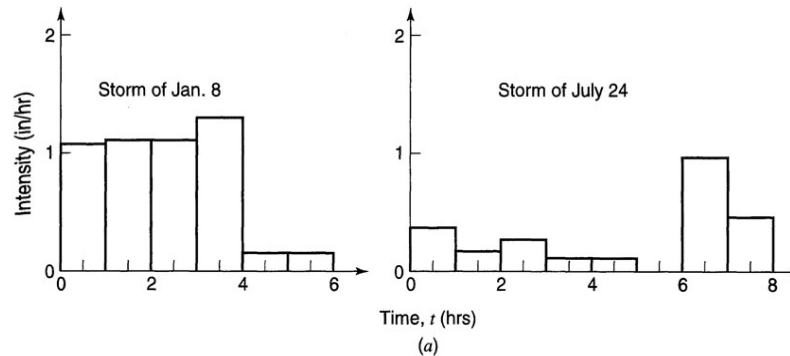

Figure 7.2.8
© John Wiley & Sons, Inc. All rights reserved.

Return Period & Probability of Exceedance of Hydrologic Events

- $T = 1/P_{\geq}$

Precipitation Data Analysis (Mays, 2012)

(See Example 2.6 , Gupta 2017)

Mon Feb 02 21:45:19 2009

Average recurrence interval (years)	
1	*
2	◇
5	○
10	□
25	×
100	—
200	△
500	+
1000	■

Precipitation Frequency Estimates (in)

ARI (years)	5 min	10 min	15 min	30 min	60 min	120 min	3 hr	6 hr	12 hr	24 hr	48 hr	4 day	7 day	10 day	20 day	30 day	45 day	60 day
1	0.38	0.60	0.73	0.97	1.18	1.38	1.48	1.77	2.04	2.39	2.74	3.15	3.66	4.13	5.55	6.96	8.73	10.4
2	0.46	0.71	0.88	1.17	1.44	1.68	1.81	2.16	2.48	2.91	3.32	3.77	4.36	4.89	6.56	8.20	10.24	12.2
5	0.55	0.85	1.05	1.43	1.80	2.12	2.30	2.78	3.17	3.72	4.21	4.67	5.28	5.88	7.73	9.49	11.65	13.9
10	0.62	0.96	1.18	1.63	2.08	2.47	2.68	3.30	3.75	4.39	4.93	5.40	6.02	6.69	8.64	10.46	12.69	15.2
25	0.71	1.09	1.34	1.90	2.46	2.94	3.21	4.05	4.58	5.37	5.99	6.46	7.06	7.84	9.88	11.70	13.95	16.7
50	0.78	1.19	1.47	2.10	2.77	3.33	3.64	4.70	5.28	6.20	6.88	7.33	7.90	8.79	10.85	12.62	14.87	17.9
100	0.85	1.28	1.60	2.31	3.08	3.73	4.09	5.40	6.05	7.10	7.83	8.27	8.78	9.78	11.82	13.49	15.71	18.9
200	0.93	1.39	1.72	2.52	3.41	4.15	4.57	6.17	6.89	8.10	8.88	9.27	9.70	10.84	12.80	14.34	16.50	19.9
500	1.03	1.52	1.90	2.81	3.88	4.75	5.24	7.31	8.13	9.58	10.41	10.77	11.06	12.33	14.12	15.42	17.47	21.1
1000	1.11	1.62	2.02	3.04	4.26	5.22	5.78	8.29	9.18	10.83	11.71	12.05	12.26	13.56	15.15	16.20	18.15	21.9

(a) Chicago, Illinois 41.820 N 87.67 W 593 feet

Figure 7.2.15a part 2

© John Wiley & Sons, Inc. All rights reserved.

Precipitation Data Analysis (Mays, 2012)

(See Example 2.6, Gupta 2017)

Partial duration based Point Precipitation Frequency Estimates - Version: 3
 41.820 N 87.67 W 593 ft

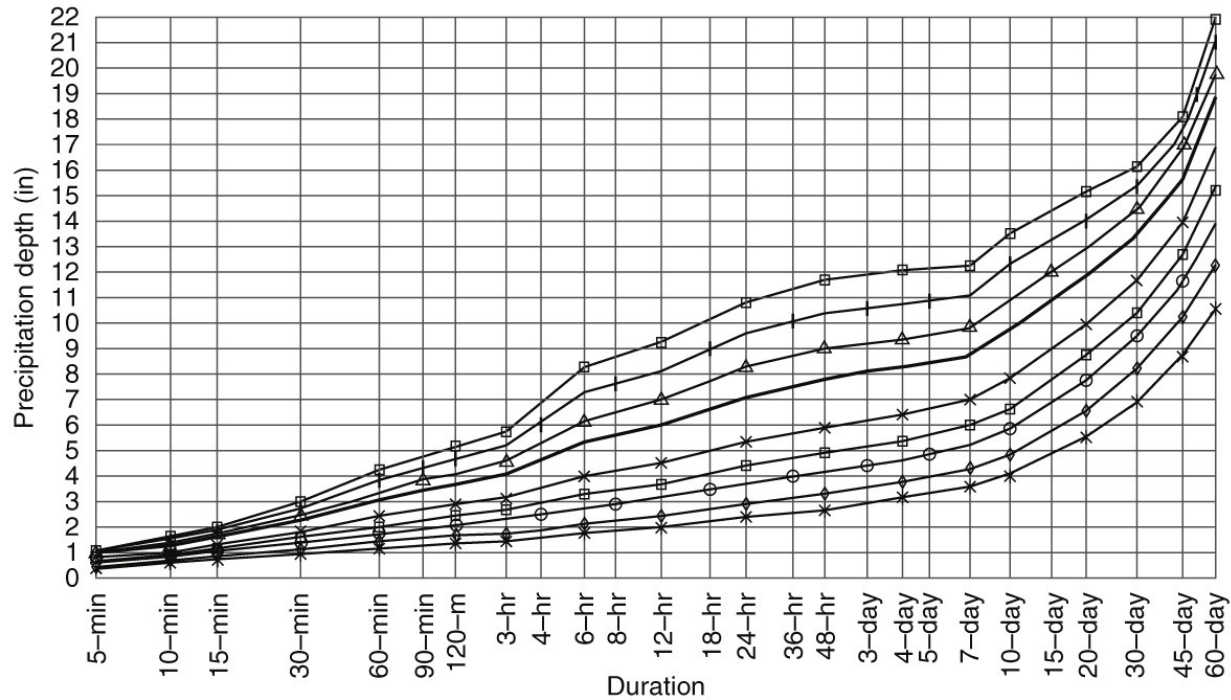

Mon Feb 02 21:45:19 2009

Average recurrence interval (years)	
1	*
2	◇
5	○
10	□
25	×
	—
	△
	+
	■
	100
	200
	500
	1000

Figure 7.2.15a part 1
 © John Wiley & Sons, Inc. All rights reserved.

Example of IDF's (Example 2.6)

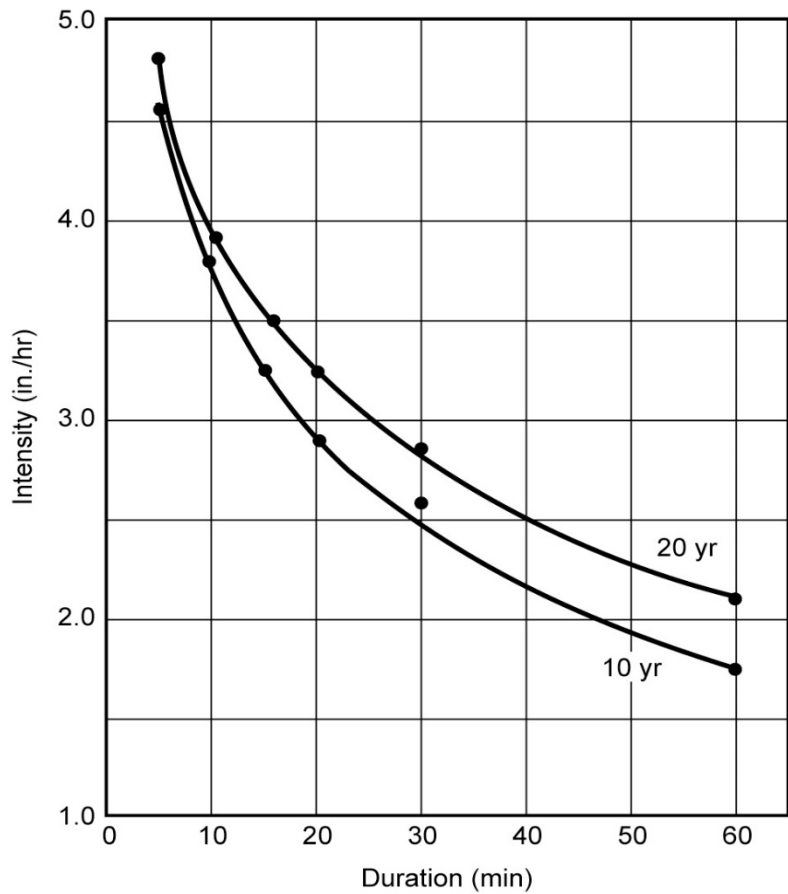
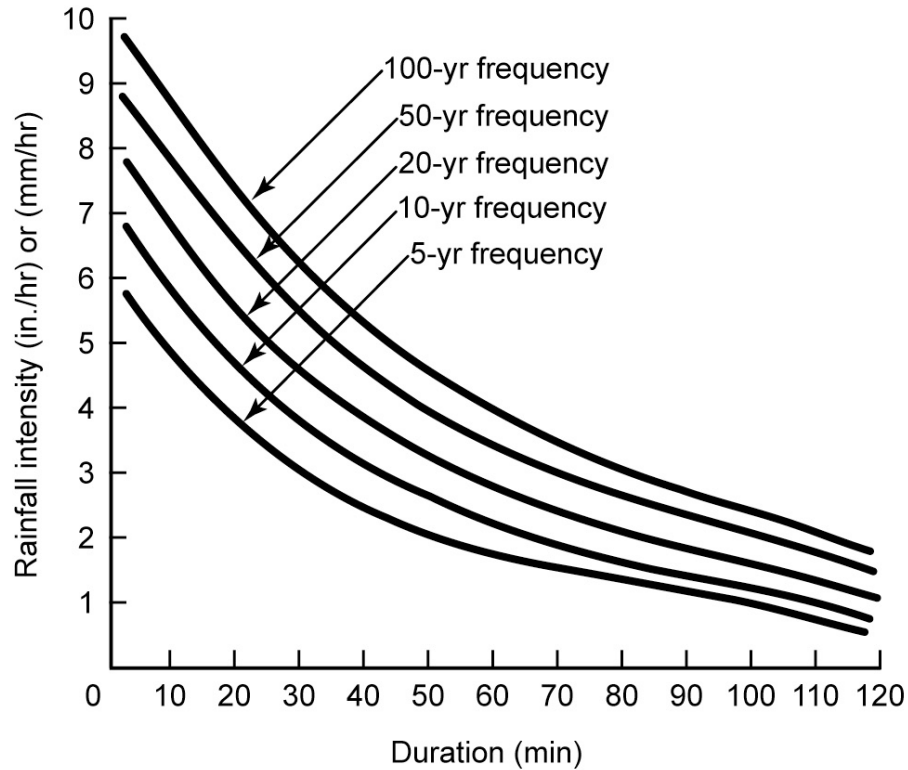

Figure 2.6 Intensity-duration-frequency curve.

Example of IDF

Figure 16.6 Intensity-duration-frequency (IDF) curves for Bridgewater, CT.



Regression Analysis: IDFs

(A common, simple relationship)

Linear Regression Analysis
for IDF-relation

$$i = \frac{A}{t+B} \quad (\text{Eq. 2.15, Gupta, 2017})$$

Considering Equation 2.15 (Gupta, 2017), which applies to a specific "return period in years, the following is an approach:

$$\frac{1}{i} = \frac{t+B}{A} \quad \therefore \frac{1}{i} = \frac{1}{A}t + \frac{B}{A}$$

t	i
-	-
-	-
-	-
-	-
⋮	⋮

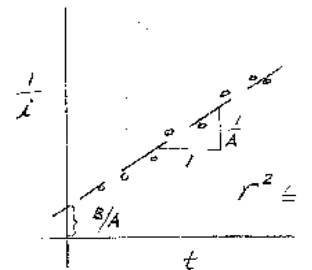

where r^2 = coefficient (or index) of determination
 r = correlation coefficient

Intensity-Duration-Frequency Curve: “IDFs”

Example 2.6 (i.e., development of IDFs)

Equation 2.15 (e.g., empirical relationship)

NWS IDF Maps: Eq. 2.15 Regional Constants

IDFs Constants for USA Regions

Figure 2.7 Map of similar rainfall characteristics (from Steel and McGhee, 1979).

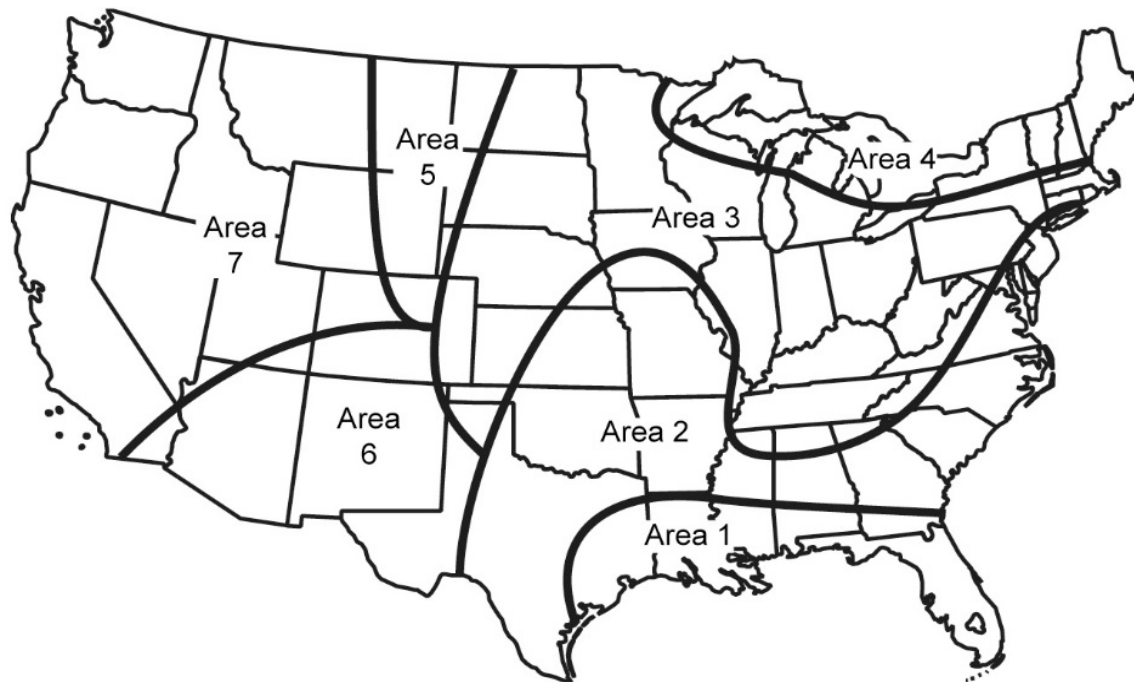

IDF General Relationships

A general equation for the IDF relations is the following:

$$i = \frac{c T^m}{t^e + f}$$

where

i = intensity

T = return period
or average recurrence interval

t = storm duration

c, e, f = best-fit statistical constants

Point to Areal Precipitation: Determination of Average

- Arithmetic or Station Average Method
(Example 2.4)
- Weighted Average Methods
 - Thiessen Polygon Method *(Example 2.4)*
 - Isohyetal Method *(Example 2.5)*

Next Generation Radar (NEXRAD)

Radar Measurements

What is it?

Reflection of electromagnetic waves from a radar antenna by raindrops

Reflection strength =

f(number and size of drops)

Distance from radar site to the area =

f(time between pulse emission and receipt of echo)

Systems

NWS installed a network of 161 Doppler radar systems in the 1990's: NEXRAD for next generation radar. WSR88D was deployed jointly by USDOE, USDOD and USDOT.

Other systems are operated by FAA, among other agencies

Application

Estimates temporal intensities over large areas

Combined with rain gage data results in estimates between areas

Less accurate than gage measurements

NEXRAD – Example NWS

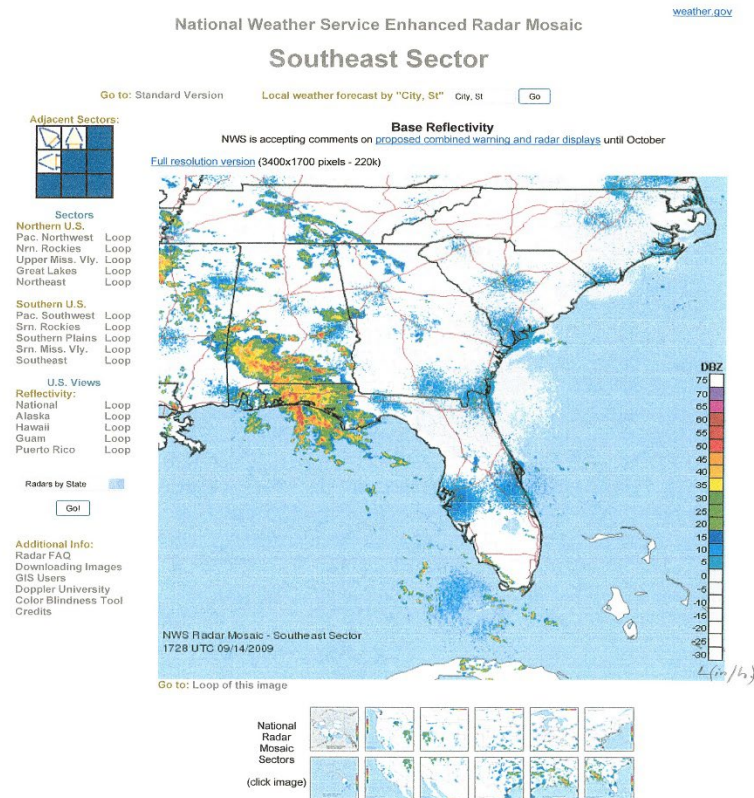

National Weather Service, NOAA
1325 East-West Highway
Silver Spring, MD 20910
Webmaster's E-mail: SR_SRH_Webmaster@noaa.gov
Page last modified: February 14, 2006

[Disclaimer](#)
[Credits](#)
[Glossary](#)

[Privacy Policy](#)
[About Us](#)
[Career Opportunities](#)

NATIONAL WEATHER SERVICE: for Safety, for Work, for Fun - FOR LIFE

NEXRAD – Example NWS (Cont.)

Base Reflectivity

Taken from the lowest (1/2°) elevation scan, base

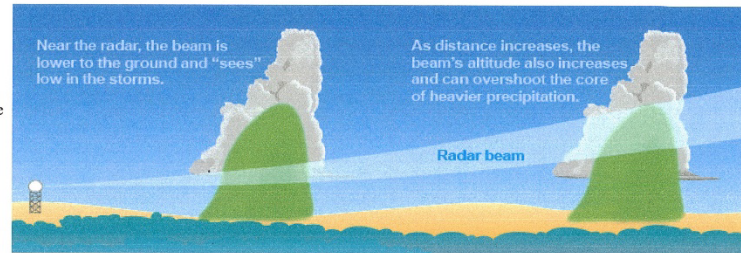

reflectivity is excellent for surveying the region around the radar to look for precipitation. However, remember the radar beam increases in elevation as distance increases from the radar. This is due, in part, to the elevation angle itself but is more because the earth's surface curves away from the beam.

This can lead to underestimating the strength and intensity of distant storms. For this reason, it is wise to always check the radar images from different locations to help provide the overall picture of the weather in any particular area.

This image (right) is a sample base reflectivity image from the Doppler radar in Frederick, OK. The radar is located in the center of the image. The colors represent the strength of returned energy to the radar expressed in values of decibels (dBZ). The color scale is located at the lower right of each image.

These dBZ values equate to approximate rainfall rates indicated in the table right.	dBZ	Rain Rate (in/hr)
These are hourly rainfall rates only and are not the actual amounts of rain a location receives. The total amount of rain received varies with intensity changes in a storm as well as the storm's motion over the ground.	65	16+
	60	8.00
	55	4.00
Also, thunderstorms can contain hail which is often a good reflector of energy. Typically, a hailstone is coated with a thin layer of water as it travels through the thunderstorm cloud. This thin layer of water on the hailstone will cause a storm's reflectivity to be greater, leading to a higher dBZ and an over estimate the amount of rain received.	52	2.50
	47	1.25
	41	0.50
	36	0.25
	30	0.10
Value of 20 dBZ is typically the point at which light rain begins. The values of 60 to 65 dBZ is about the level where 3/4" hail can occur. However, a value of 60 to 65 dBZ does not mean that severe weather is occurring at that location.	20	Trace
	< 20	No rain

Severe weather may be occurring with values less (or greater) than 60 to 65 dBZ due to...

- Hail that is totally frozen (without a thin layer of water in the surface). "Dry hail" is a very poor reflector of energy and can lead to an *underestimate* of a storm's intensity.
- Atmospheric conditions such a ducting. When ducting occurs, the radar beam is refracted into the ground (indicating stronger storms than what are actually occurring). However a worse case is

Hydrologic Cycle

Evaporation & Transpiration

CWR 3540: Water Resources Engineering
FIU Department of Civil & Environmental Engineering
Professor Fuentes

Evaporation & Transpiration

(“losses from runoff or groundwater)

- Evaporation: water vaporized into atmosphere from free water surface and land areas
- Transpiration: *water absorbed by plants and crops and eventually discharged into the atmosphere*
- *About 70% of the precipitation in the USA is returned to the atmosphere as either E, T or both, ET*

Evaporation Estimates (and Measurements) from Free-Water Bodies

- Comparative methods: Pan Evaporation and Atmometers
- Aerodynamic Method
- Energy Balance Method
- Combination Method (of the aerodynamic and energy methods)

Standard NWS Evaporation Pans (with Cup Anemometers)



Figure 12.1.12a
wikimedia commons

Class A Evaporation Pan

$(E_L = KE_p)$



Figure 12.1.12b
Courtesy of the National Weather Service

Evaporation Pans

(from a free-water body, e.g., a lake)

- Most common method: Uses the Standard National Weather Service Class A Pan (4 ft diameter x 10 in depth, wooden frame 12 in above ground)

- Equation 3.1: $E_L = K \times E_p$

E_L = evaporation from water body

E_p = evaporation from the pan

K = pan coefficient (0.6 to 0.8 range, and average of 0.7)

Equation 3.2, Kohler and Parmele (1967) corrects K to a K' for monthly and daily evaporation losses, based on vapor pressure measurements:

$$E_L = K' \{(e_{sl} - e_z)/(e_{sp} - e_z)\} \times E_p$$

Refer to Example 3.1

Aerodynamic Method Sketch (Source: Mays, 2012)

It considers the transport of water vapor by the turbulence of the wind over a natural surface

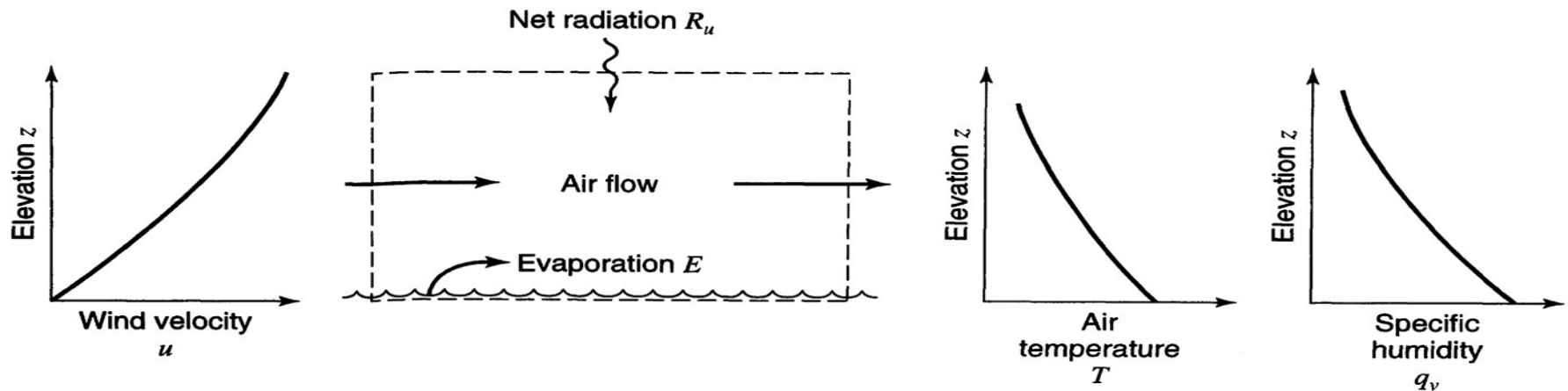

Figure 7.3.4
© John Wiley & Sons, Inc. All rights reserved.

Aerodynamic Method

- Widely used for lakes and reservoirs
- Equations: 3.3, 3.4 and 3.5, with Table 3.1
 - $E_a = M(e_s - e_z) u_z$ (LT⁻¹), where
 - e_a = evaporation by aerodynamic method
 - M = mass transfer coefficient
 - e_s = saturation vapor pressure at water T
 - e_z = air vapor pressure at level z [= RH(e_z^o)]
 - RH = relative humidity
 - u_z = wind velocity at level Z
- See Example 3.2 and Additional Example in Module 2

Reference Height for Roughness

(Used when wind speed is measured at an elevation other than that for determination
(See Equation 3.5 or logarithmic law that accounts for surface roughness))

Table 3.1 Reference Height for Roughness

Roughness class	Roughness length, Z_0 , m	Landscape
0	0.0002	Water surface
0.5	0.0024	Open terrain
1	0.03	Open agricultural area
1.5–2.5	0.055–0.2	Agricultural land with houses
3.0	0.4	Village, small town, forests
3.5	0.8	Larger cities
4.0	1.6	Very large cities

Energy Balance Method Sketch

Figure 3.1 Energy inflow and outflow from a water body and a cropped area.

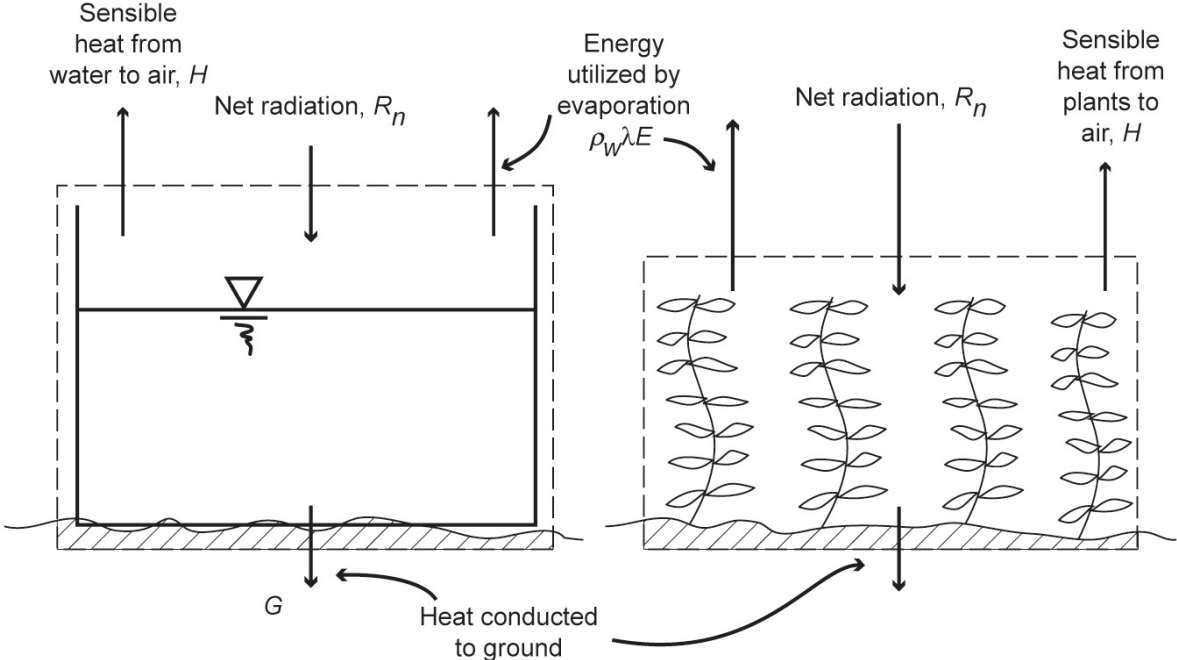

Energy Method

- It is highly data intensive
- Equation 3.8, estimated as Eq. 3.9 or 3.10 plus Eq. 3.11 supported by Equations 3.7, 3.8 and Table 3.1
 - $E_r = [R_n - G]/[\rho_w \lambda (1 + \beta)]$ [LT^{-1}], where
 - Where, $R_n =$ net radiant energy ($= S_b + R_b$), which are the net short-wave radiation and the net long-wave radiation, respectively
- See Example 3.3

Combined Method (of Penman)

- Weighted estimate from both the aerodynamic and energy methods
- Equation 3.13
 - $E = \Delta/[\Delta + \gamma] \times E_r + \Delta/[\Delta + \gamma] \times E_a$, where
 - E_r = evaporation by the energy method
 - E_a = evaporation by the aerodynamic method
 - Δ = gradient of saturated water pressure, Table 3.2
- See Example 3.4

C_p, e_s, Δ of e_s, γ , and λ

Table 3.2 Specific Heat, Saturated Vapor Pressure, Gradient, Psychrometric Constant, and Latent Heat of Vaporization at Standard Atmospheric Pressure

Temperature °C	Specific Heat c_p , kJ/kg °C	Saturated vapor pressure e_s , kPa	Gradient of saturated vapor pressure Δ , kPa °C ⁻¹	Psychrometric constant γ , kPa °C ⁻¹	Latent heat of vaporization λ , MJ/kg
0	4.218	0.611	0.044	0.0654	2.501
1	4.215	0.657	0.047	0.0655	2.499
2	4.211	0.706	0.051	0.0656	2.496
3	4.208	0.758	0.054	0.0656	2.494
4	4.205	0.814	0.057	0.0657	2.492
5	4.202	0.873	0.061	0.0658	2.489
6	4.200	0.935	0.065	0.0659	2.487
7	4.198	1.002	0.069	0.0659	2.484
8	4.196	1.073	0.073	0.0660	2.482
9	4.194	1.148	0.078	0.0660	2.480
10	4.192	1.228	0.082	0.0661	2.478
11	4.191	1.313	0.087	0.0661	2.475
12	4.190	1.403	0.093	0.0662	2.473
13	4.188	1.498	0.098	0.0663	2.470
14	4.187	1.599	0.104	0.0663	2.468
15	4.186	1.706	0.110	0.0664	2.466
16	4.185	1.819	0.116	0.0665	2.463
17	4.184	1.938	0.123	0.0665	2.461
18	4.184	2.065	0.130	0.0666	2.459
19	4.183	2.198	0.137	0.0666	2.456
20	4.182	2.337	0.145	0.0667	2.454
21	4.182	2.488	0.153	0.0668	2.451
22	4.181	2.645	0.161	0.0668	2.449
23	4.181	2.810	0.170	0.0669	2.447
24	4.180	2.985	0.179	0.0670	2.444
25	4.180	3.169	0.189	0.0670	2.442
26	4.180	3.363	0.199	0.0671	2.440
27	4.179	3.567	0.209	0.0672	2.437
28	4.179	3.781	0.220	0.0672	2.435
29	4.178	4.007	0.232	0.0673	2.433
30	4.178	4.243	0.243	0.0674	2.430
31	4.178	4.494	0.256	0.0674	2.428
32	4.178	4.756	0.269	0.0675	2.425
33	4.178	5.032	0.282	0.0676	2.423
34	4.178	5.321	0.296	0.0676	2.421
35	4.178	5.625	0.311	0.0677	2.418
36	4.178	5.943	0.326	0.0678	2.416
37	4.178	6.277	0.342	0.0678	2.414
38	4.178	6.627	0.358	0.0679	2.411
39	4.178	6.994	0.375	0.0680	2.409

ET from a Drainage basin

- Evapotranspirometers (i.e., experimental devices also referred to as *“lysimeters”*, if *drainage from the soil is also accounted for*)
- Penman-Monteith ET Equation (after Eq. 3.13)
 - Equation 3.16 (p. 77), which defines two “resistances”, one the aerodynamic resistance from a water surface by wind as water vapor transfer into the air above, r_a , and the resistance of water vapor to move from inside the plant to the air outside, r_s

Evapotranspirometers

(e.g., “lysimeters”)

Example of Field Experiment



Example of System Drawing

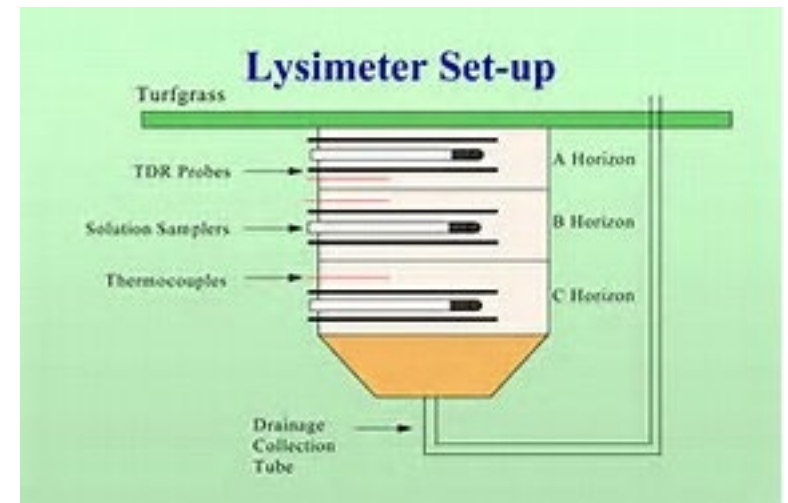

Hydrologic Cycle

Infiltration & Runoff

CWR 3540: Water Resources Engineering
FIU Department of Civil & Environmental Engineering
Professor Fuentes

Double-ring Infiltrometer

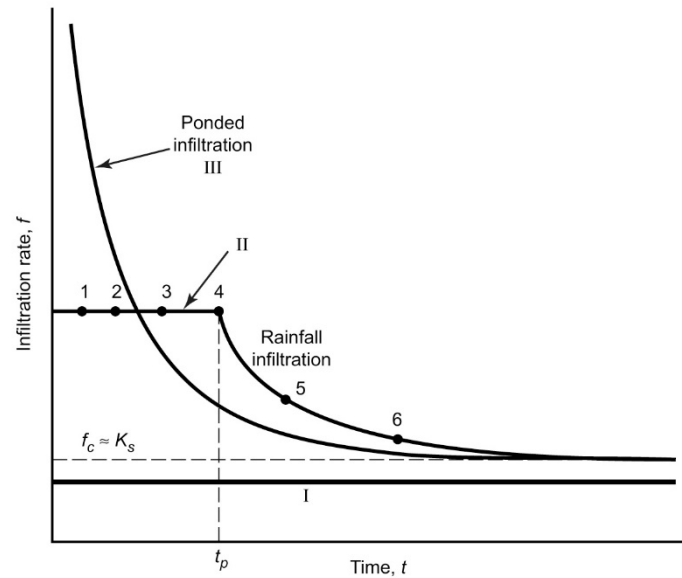

Figure 12.1.15
www.wikipedia.com

Infiltration Capacity Estimation

- Theory-based:
 - Infiltration Capacity and
 - Non-Linear Loss Rate Function
- Empirical:
 - Horton's Equation
 - Other
- Methods for Direct Runoff that account for infiltration
 - Infiltration-Index Method
 - NRCS (or "CN") Method

Infiltration-Rainfall Behavior



(a)

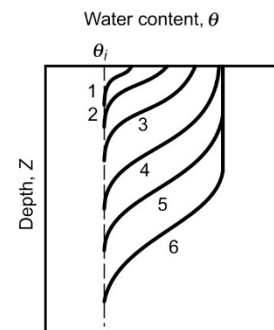

(b)

Rainfall Intensity and Infiltration Rate

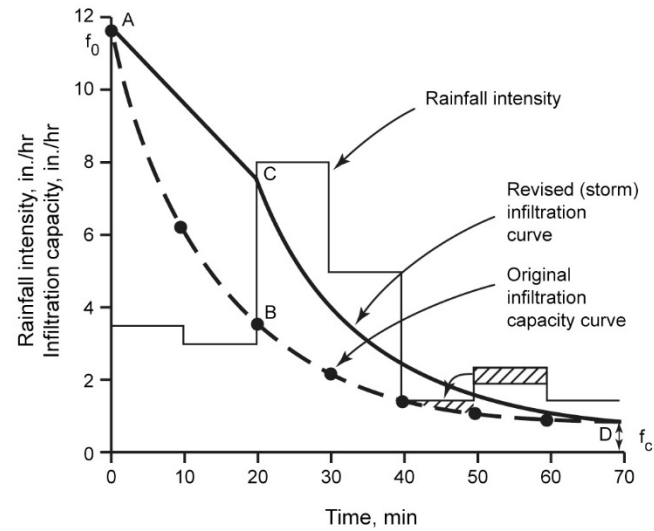

Figure 4.3 Rainfall intensity and infiltration capacity curves.

Horton's Infiltration Model

- Horton (1939):
 - $f_p = (f_o - f_c) e^{-kt} + f_c$ (Eq. 4.2, p. 96), where
 - f_o = initial infiltration rate
 - f_c = final constant infiltration rate, equal to *“apparent “soil” saturated hydraulic conductivity”*
 - k = factor representing the rate of decrease (also referred to as *“recession constant”*)
 - *See handout and example in course website*

Horton's Model: Example 4.1

Table 4.1 Infiltration Capacity and Cumulated Infiltration

(1) Time min	(2) f_p in./hr	(3) Δt^a min	(4) Average f_p^b in./hr	(5) ΔF^c in.	(6) F^d in.
0	11.66				
		10	8.94	1.49	1.49
10	6.21				
		10	4.86	0.81	2.30
20	3.50				
		10	2.83	0.47	2.77
30	2.16				
		10	1.83	0.31	3.08
40	1.49				
		10	1.33	0.22	3.30
50	1.16				
		10	1.08	0.18	3.48
60	0.99				
		10	0.95	0.16	3.64
70	0.91				

^a Successive difference col. 1

^b Average of two successive values of col. 2

^c col. 3 \times col. 4 \times $\left[\frac{1 \text{ hr}}{60 \text{ min}} \right]$

^d Cumulation of col. 5

Horton's Model: Example 4.1

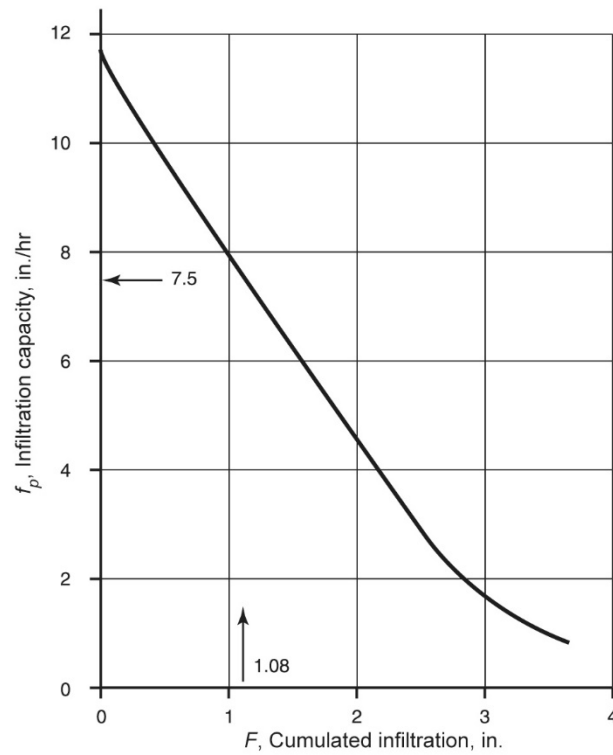

Figure 4.4 Cumulated infiltration curve.

Horton's Model: Example 4.1

Table 4.2 Revised Infiltration Capacity for the Storm of Example 4.1

(1) t' min	(2) Time from beginning of storm t min	(3) f_p using t' in./hr
0	20	7.5
10	30	4.14
20	40	2.47
30	50	1.65
40	60	1.24
50	70	1.03

Horton's Model: Example 4.1

Table 4.3 Computations of Rainfall Excess by the Horton Method

(1)	(2)	(3)	(4)	(5)	(6)	(7)	(8)
Time min	Revised infiltration capacity f'_p in./hr	Δt min	Average f'_p in./hr	Cumulated ΔF in.	Rainfall intensity i in./hr	$\Delta P = i\Delta t^a$ in.	$RO^b = \Delta P - \Delta F$ in.
0							
10							
20	7.5						
		10	5.82	0.97	8.0	1.33	0.36
30	4.14						
		10	3.31	0.55	5.0	0.83	0.28
40	2.47						
		10	2.06	0.34	1.5	0.25	-0.09
50	1.65						
		10	1.45	0.24	2.4	0.4	0.16
							(-).09 ^c
60	1.24						= 0.07
		10	1.13	0.19	1.5	0.25	0.06
70	1.03						

Note: Computations of col. (3), (4) and (5) are similar to Table 4.1.

^a Col. 6 \times col. 3 \times $\left[\frac{1 \text{ hr}}{60 \text{ min}} \right]$

^b Col. 7 - col. 5

^c Negative value of the previous step.

Infiltration Index Method to Runoff

- See types of indices, including the simplest ϕ -Index option and its procedure in Section 4.5.
- Applications: Examples 4.6 and 4.7

Representation of the ϕ -Index

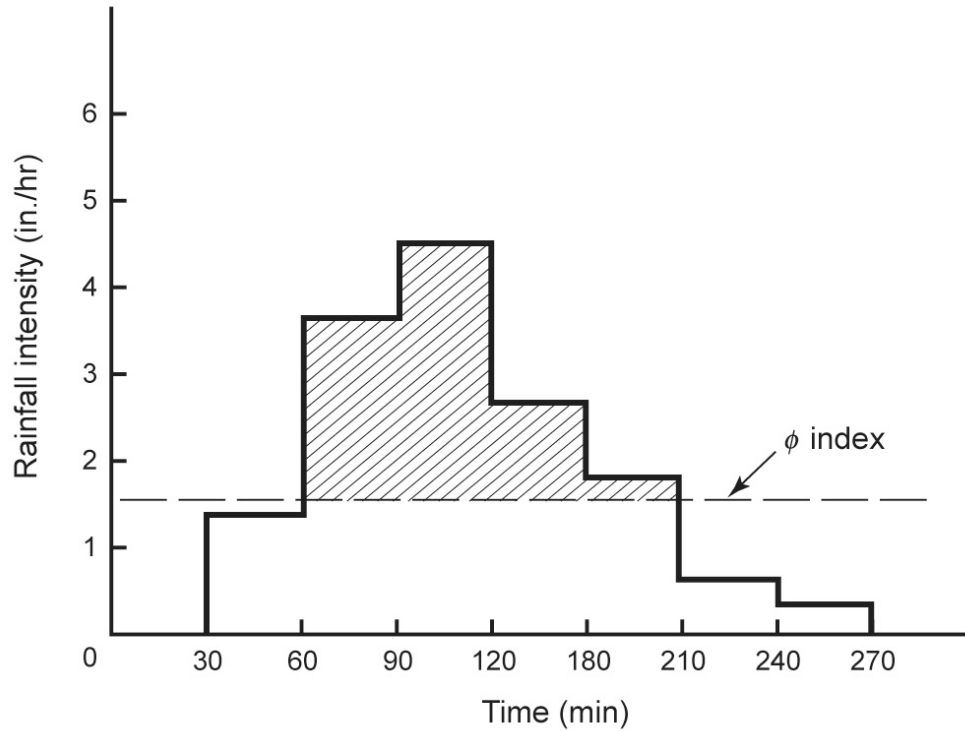

Figure 4.9
Representation
of the ϕ index.

NRCS (“CN”) Method for Direct Runoff

- $Q = (P - 0.2S)^2 / (P + 0.8S)$ [L], where
 - Q = accumulated runoff depth over the drainage area
 - P = accumulated rainfall depth
 - S = potential maximum retention of water by soil
- $CN = 1000 / (10 + S)$, where
 - CN = curve number (See Tables 4.10, 4.11, 4.12 and 4.13)

Hydrologic Soils Types

Table 4.10 Hydrologic Soil Groups

Group	Minimum Infiltration Rate (in./hr)	Texture ^a
A	0.3–0.45	Sand, loamy sand, or sandy loam
B	0.15–0.30	Silt loam or loam
C	0.05–0.15	Sandy clay loam
D	0–0.05	Clay loam, silty clay loam, sandy clay, silty clay, or clay

^a Reproduced from U.S. Soil Conservation Service (1986).

Curve Numbers for AMC II

Table 4.11 Curve Numbers for Antecedent Moisture Condition II

Use	Cover Type	Treatment	Hydrologic Condition	Hydrologic soil group				
				A	B	C	D	
Urban	Fully developed Open space (lawns, parks)		Poor (cover < 50%)	68	79	86	89	
			Fair	49	69	79	84	
			Good (grass cover > 75%)	39	61	74	80	
		Impervious areas (paved parking, roofs, driveways, paved roads)		98	98	98	98	
		Dirt roads		72	82	87	89	
	Urban districts	Commercial and business		89	92	94	95	
		Industrial		81	88	91	93	
		Developing areas		77	86	91	94	
	Cultivated agriculture lands	Fallow	Bare soil	...	77	86	91	94
		Row crops	Straight row	Poor	72	81	88	91
Straight row			Good	67	78	85	89	
Contoured			Poor	70	79	84	88	
Contoured			Good	65	75	82	86	
Contoured and terraced			Poor	66	74	80	82	
Contoured and terraced			Good	62	71	78	81	
Small grain		Straight row	Poor	65	76	84	88	
		Straight row	Good	63	75	83	87	
		Contoured	Poor	63	74	82	85	
		Contoured	Good	61	73	81	84	
		Contoured and terraced	Poor	61	72	79	82	
		Contoured and terraced	Good	59	70	78	81	
Close-seeded legumes or rotation meadow		Straight row	Poor	66	77	85	89	
		Straight row	Good	58	72	81	85	
		Contoured	Poor	64	75	83	85	
		Contoured	Good	55	69	78	83	
		Contoured and terraced	Poor	63	73	80	83	
	Contoured and terraced	Good	51	67	76	80		

(continued)

Curve Numbers for AMC II

Table 4.11 Curve Numbers for Antecedent Moisture Condition II (Continued)

Use	Cover Type	Treatment	Hydrologic Condition	Hydrologic soil group				
				A	B	C	D	
Agriculture lands	Pasture or range		Poor	68	79	86	89	
			Fair	49	69	79	84	
			Good	39	61	74	80	
		Meadow		30	58	71	78	
	Woods		Poor	45	66	77	83	
			Fair	36	60	73	79	
			Good	30	55	70	77	
		Farmsteads (building, lanes, driveways)		59	74	82	86	
	Arid and semiarid rangelands	Herbaceous (mixture of grass, weeds, and low-growing brush)		Poor (< 30% ground cover)		80	87	93
				Fair		71	81	89
			Good (> 70% cover)		62	74	85	
Oak–aspen (mountain brush mixture)			Poor		66	74	79	
			Fair		48	57	63	
			Good		30	41	48	
Pinyon–juniper			Poor		75	85	89	
			Good		41	61	71	
Sagebrush with grass understory			Poor		67	80	85	
			Good		35	47	55	
Desert shrub			Poor	63	77	85	88	
			Fair	55	72	81	86	
		Good	49	68	79	84		

Source: Condensed from U.S. Soil Conservation Service (1986).

Curve Numbers for AMC II

Table 4.12 Antecedent Moisture Condition

Category	Condition
I	Dry soil but not to the wilting point
II	Average conditions
III	Saturated soils; heavy rainfall or light rainfall with low temperatures has occurred in the last 5 days

Curve Numbers for AMC I and II As Function of AMC II

Table 4.13 Cross-Linking of Curve Numbers for Various Antecedent Moisture Conditions

Curve Number for Condition II	Corresponding Curve Number for Condition	
	I	III
100	100	100
95	87	99
90	78	98
85	70	97
80	63	94
75	57	91
65	45	83
60	40	79
55	35	75
50	31	70
45	27	65
40	23	60
35	19	55
30	15	50
25	12	45
20	9	39
15	7	33
10	4	26
5	2	17
0	0	0

Source: U.S. Soil Conservation Service (1972).

Runoff Depth As Function of CN

Table 4.14 Runoff Depth for Selected CNs and Rainfall Amounts^a

Rainfall	Runoff Depth (in.) for Curve Number of:												
	40	45	50	55	60	65	70	75	80	85	90	95	98
0.5	0.00	0.00	0.00	0.00	0.00	0.00	0.00	0.00	0.00	0.01	0.06	0.17	0.32
1.0	0.00	0.00	0.00	0.00	0.00	0.00	0.00	0.03	0.08	0.17	0.32	0.56	0.79
1.2	0.00	0.00	0.00	0.00	0.00	0.00	0.03	0.07	0.15	0.27	0.46	0.74	0.99
1.4	0.00	0.00	0.00	0.00	0.00	0.02	0.06	0.13	0.24	0.39	0.61	0.92	1.18
1.6	0.00	0.00	0.00	0.00	0.01	0.05	0.11	0.20	0.34	0.52	0.76	1.11	1.38
1.8	0.00	0.00	0.00	0.00	0.03	0.09	0.17	0.29	0.44	0.65	0.93	1.29	1.58
2.0	0.00	0.00	0.00	0.02	0.06	0.14	0.24	0.38	0.56	0.80	1.09	1.48	1.77
2.5	0.00	0.00	0.02	0.08	0.17	0.30	0.46	0.65	0.89	1.18	1.53	1.96	2.27
3.0	0.00	0.02	0.09	0.19	0.33	0.51	0.71	0.96	1.25	1.59	1.98	2.45	2.77
3.5	0.02	0.08	0.20	0.35	0.53	0.75	1.01	1.30	1.64	2.02	2.45	2.94	3.27
4.0	0.06	0.18	0.33	0.53	0.76	1.03	1.33	1.67	2.04	2.46	2.92	3.43	3.77
4.5	0.14	0.30	0.50	0.74	1.02	1.33	1.67	2.05	2.46	2.91	3.40	3.92	4.26
5.0	0.24	0.44	0.69	0.98	1.30	1.65	2.04	2.45	2.89	3.37	3.88	4.42	4.76
6.0	0.50	0.80	1.14	1.52	1.92	2.35	2.81	3.28	3.78	4.30	4.85	5.41	5.76
7.0	0.84	1.24	1.68	2.12	2.60	3.10	3.62	4.15	4.69	5.25	5.82	6.41	6.76
8.0	1.25	1.74	2.25	2.78	3.33	3.89	4.46	5.04	5.63	6.21	6.81	7.40	7.76
9.0	1.71	2.29	2.88	3.49	4.10	4.72	5.33	5.95	6.57	7.18	7.79	8.40	8.76
10.0	2.23	2.89	3.56	4.23	4.90	5.56	6.22	6.88	7.52	8.16	8.78	9.40	9.76
11.0	2.78	3.52	4.26	5.00	5.72	6.43	7.13	7.81	8.48	9.13	9.77	10.39	10.76
12.0	3.38	4.19	5.00	5.79	6.56	7.32	8.05	8.76	9.45	10.11	10.76	11.39	11.76
13.0	4.00	4.89	5.76	6.61	7.42	8.21	8.98	9.71	10.42	11.10	11.76	12.39	12.76
14.0	4.65	5.62	6.55	7.44	8.30	9.12	9.91	10.67	11.39	12.08	12.75	13.39	13.76
15.0	5.33	6.36	7.35	8.29	9.19	10.04	10.85	11.63	12.37	13.07	13.74	14.39	14.76

^a Interpolate the values shown to obtain runoff depths for CNs or rainfall amounts not shown.

Source: U.S. Soil Conservation Service (1986).

Hydrologic Cycle

Streamflow

CWR 3540: Water Resources Engineering
FIU Department of Civil & Environmental Engineering
Professor Fuentes

Streams, Rivers & Canals





Stream Channel Velocity-Distribution

Figure 8.5 Typical velocity distribution in a stream channel.

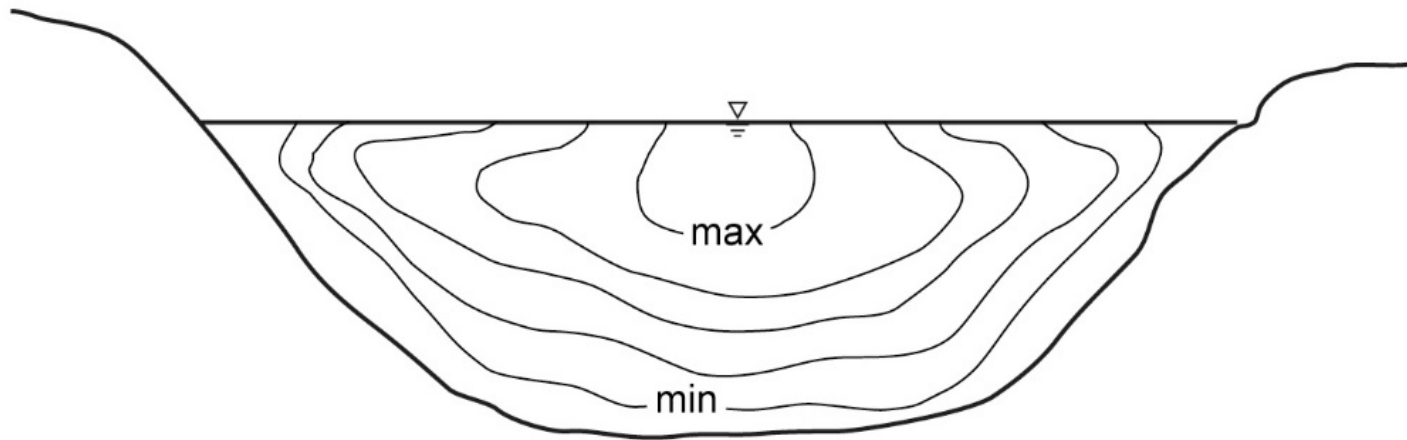

Determination of Streamflow (or Discharge)

- *Streamflow* quantity, space distribution and time variability are required to plan and design any surface water supply or hydraulic structure.

Measurement & Estimation

- Measurement of Streamflow
 - Direct measurement or stream gaging
 - Through hydraulic devices (for small stream and open channels, for instance, weirs, flumes, etc.)
 - Indirect measurement of peak flows
- Estimation of Streamflow
 - Application of precipitation data
 - Extension of gage-sites data
 - Generation of synthetic flows
 - Use of generalized data, charts, tables and empirical approaches

Stream Gaging

- Stream gaging or hydrometry measures the water stage (level or depth) and discharge at a gaging station to collect a continuous record
- A number of gaging stations in a watershed, basin or drainage area form a hydrologic network
- The US Geological Survey operates a nationwide stream-gaging network (+7,600)

Stage-Discharge Relationship: ("Rating Curve")

Figure 8.23 Log-log plot of stage and discharge data for Example 8.11.

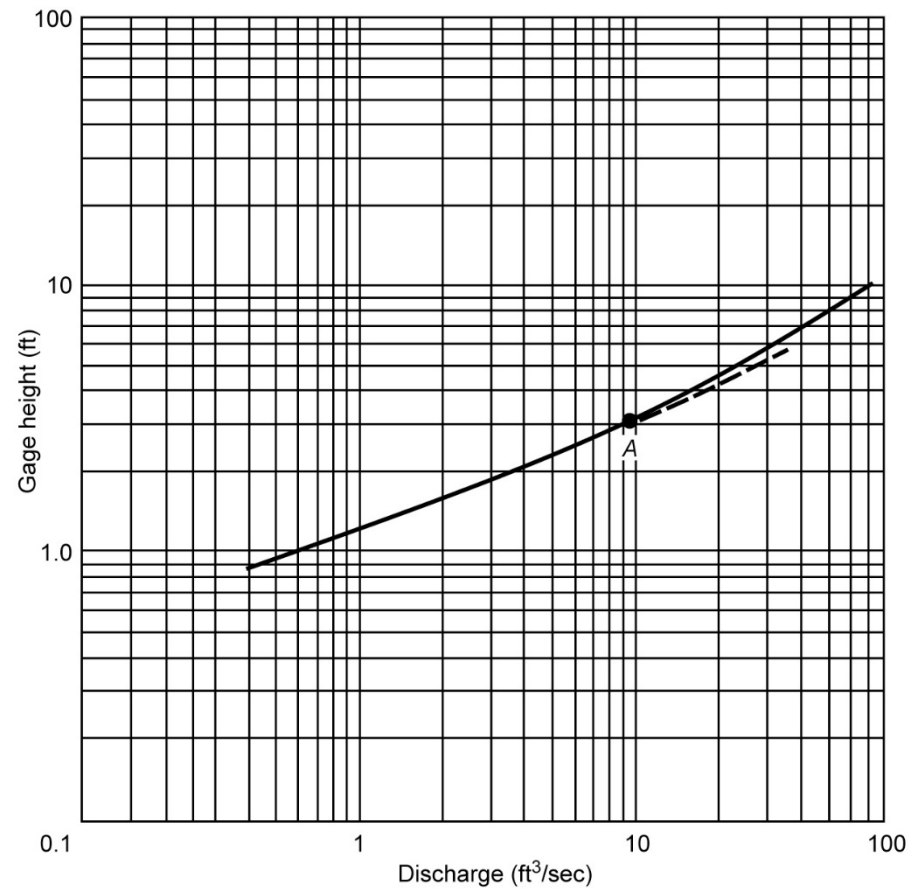

Stage Measurement

- Stilling Well with Float Sensor (Fig. 8.1)
- Pressure System with Bubble-Gage Sensor (Fig. 8.2) (e.g., nitrogen)
- Radar Stage Measurement (Fig. 8.3) (e.g., sensor-emitted electromagnetic waves echoed back to the sensor)

Stage Measurement

Figure 8.1 Stilling well for a float-type recorder (from Herschy, 1985a).

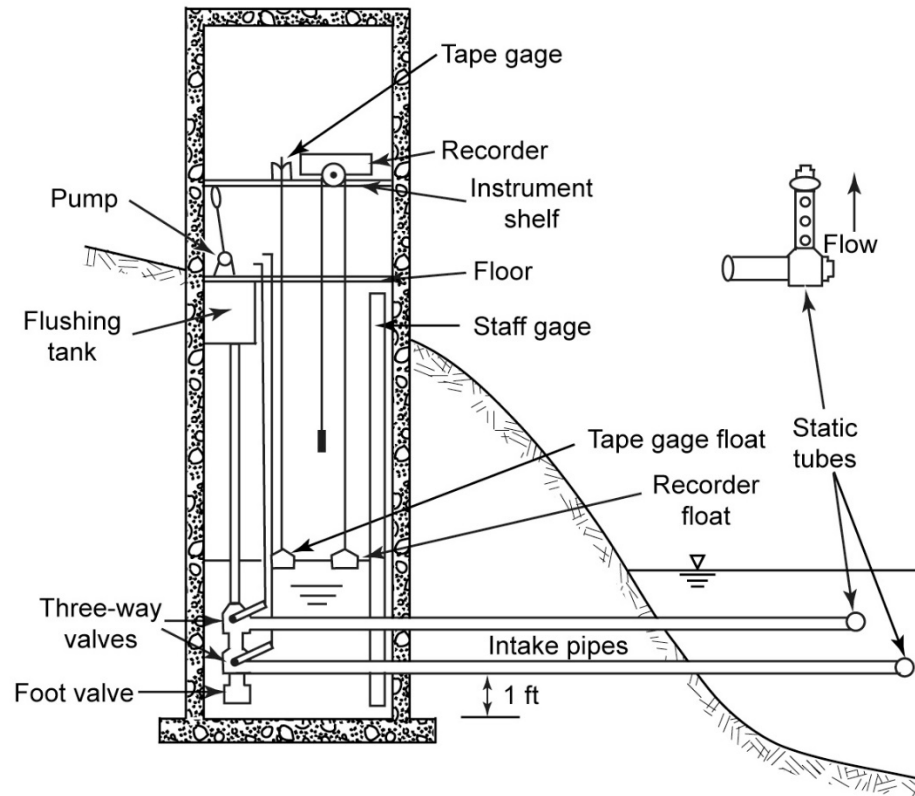

Bubble-gage Measurement

Figure 8.2 Bubble-gage installation (from Herschy, 1985a).

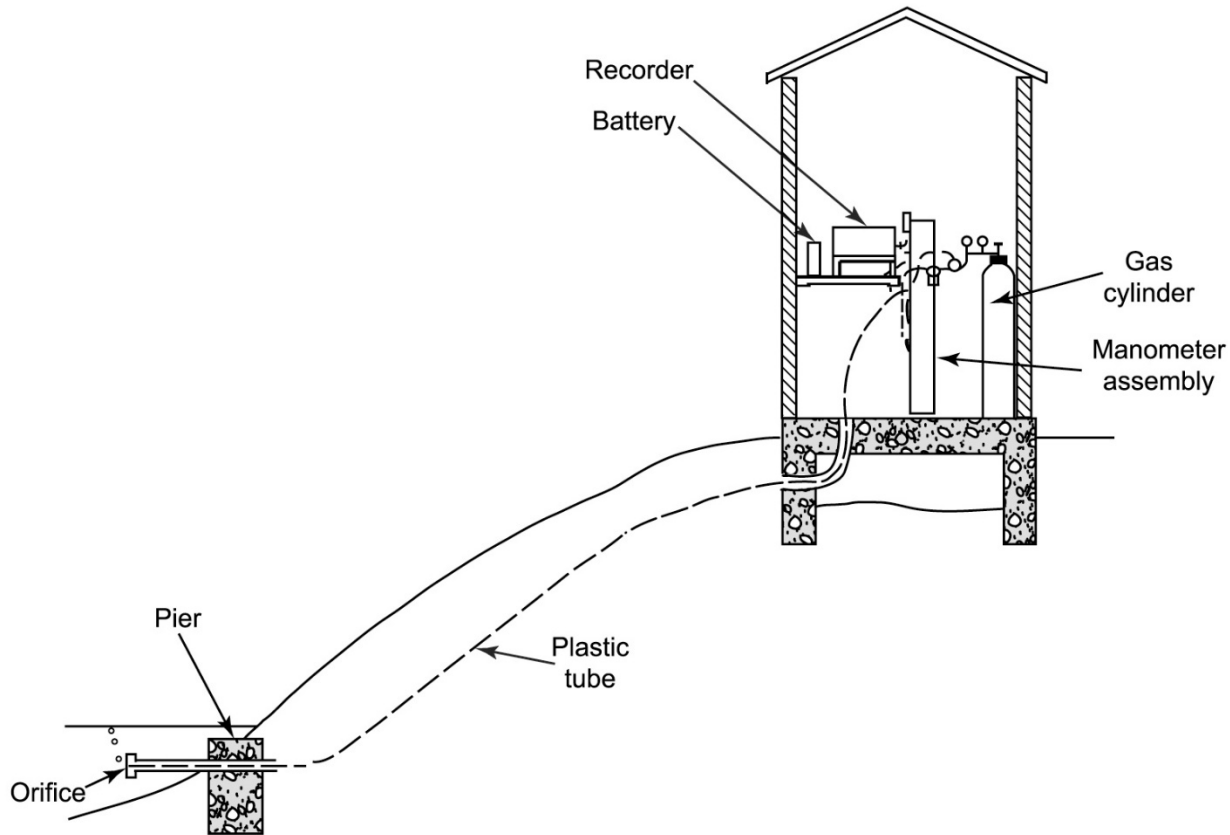

Radar Stage Measurement

(Figure 8.3, Gupta, 2017)

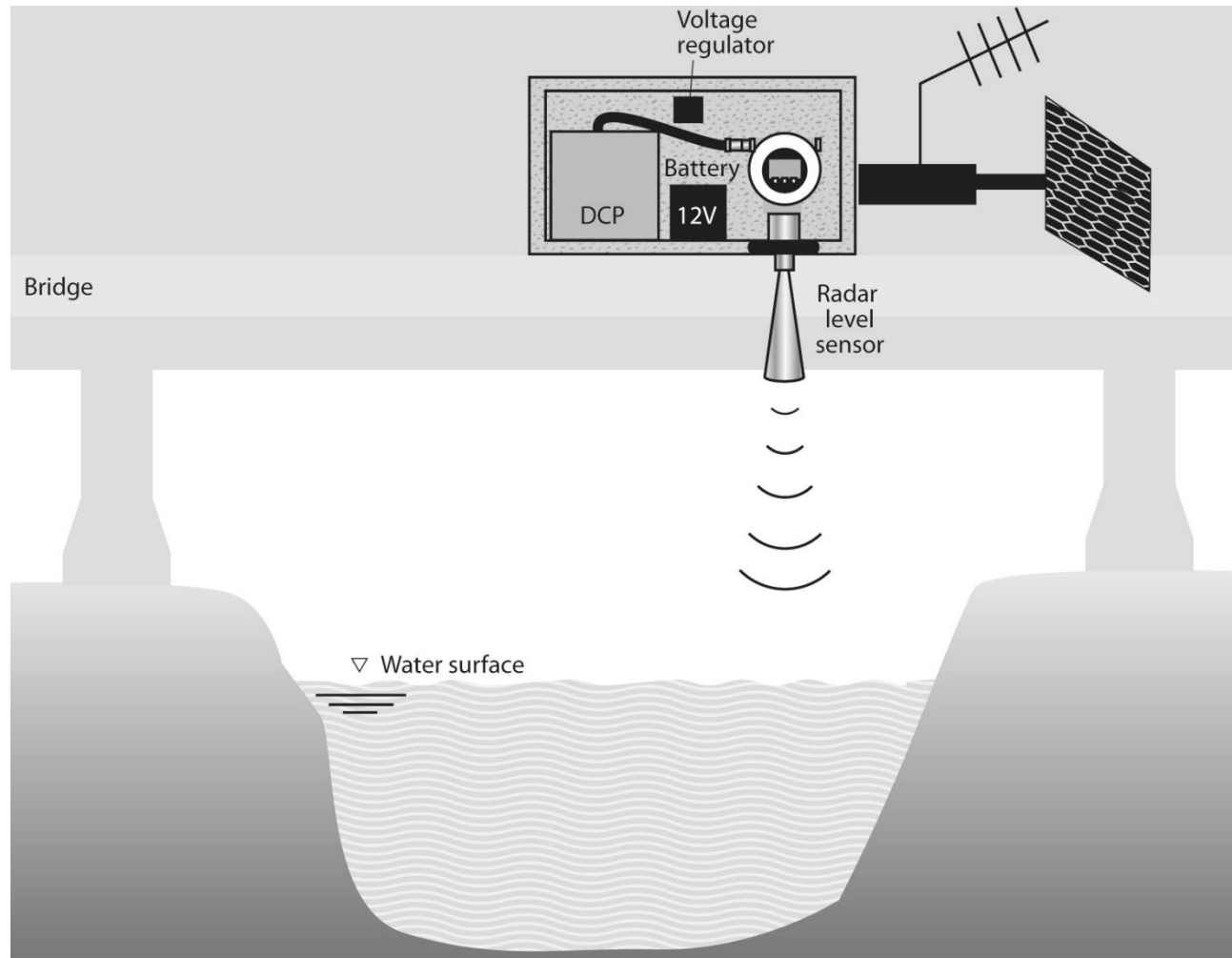

Single Stage-Discharge Relation

- Equation 8.25:

- $Q = A (h \pm a)^n$ where

- Q = discharge

- H = gage height

- a = stage reading at zero flow (i.e., datum correction)

- A, n = constants to be determined for each case

- Or*

- Log Q = n log (h ± a) + log A (of the form Y = M X + N)

- See Sections 8.19.1 and 8.21 for regression analysis

Defining “a”: Trial and Error Procedure

Figure 8.22 Trial-and-error procedure to determine the stage of zero flow.

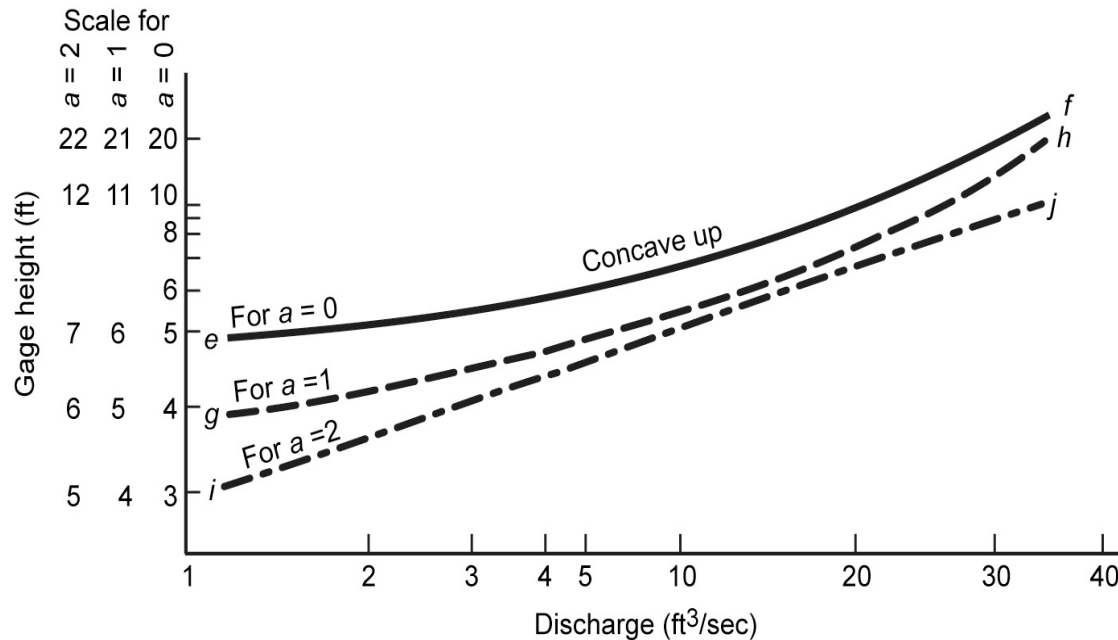

Discharge Measurement

- Volumetric flow rate: $Q = \int a \cdot dv = \sum a_i \cdot v_i$ ($L T^{-3}$)
- Methods of measurement:
 - Current meter method (e.g., “Price”; mechanical meter, Fig. 8.4)
 - Hydroacoustic method (Acoustic Doppler velocity meter, ADCP, or sound pulse of certain frequency from and reflected back to transducer), with GPS to track the stream bottom (Fig. 8.16)
 - Ultrasonic method (ultrasonic velocity meter, UVM)
 - Electromagnetic method (based on electromagnetic induction, electrodes on banks and coils buried in stream section)

Methods to Measure Velocity and Area to Determine Discharge

- Current Meter
- Hydroacoustic (e.g., acoustic Doppler velocity meter, ADVN): sent and reflected back acoustic signal of 10 MHz frequency
- Ultrasonic (ultrasonic velocity meter, UVM)
- Electromagnetic (based on electromagnetic induction): measures electric current from water – a conductor - moving in magnetic field

Price Current Meter

Figure 8.4 Assembly of a type AA current meter (courtesy of Geophysical Instrument and Supply Co.).

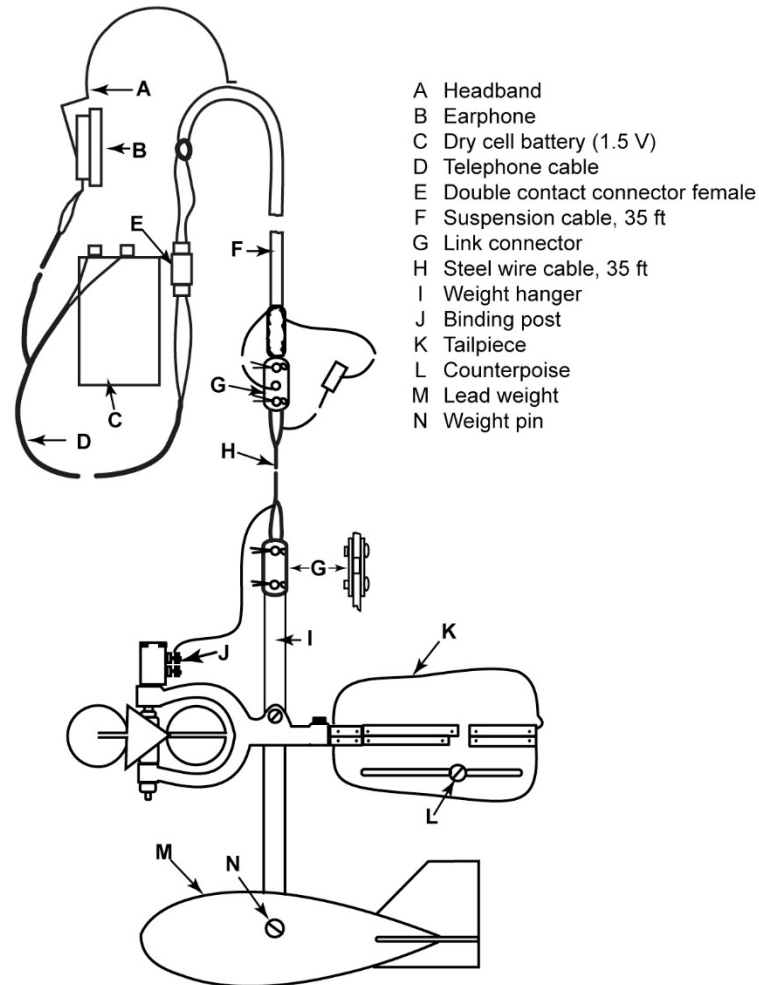

Discharge Computation

by Current Meter – Mid-Section Method

Example 8.7

Figure 8.9 Subsection in the midsection method.

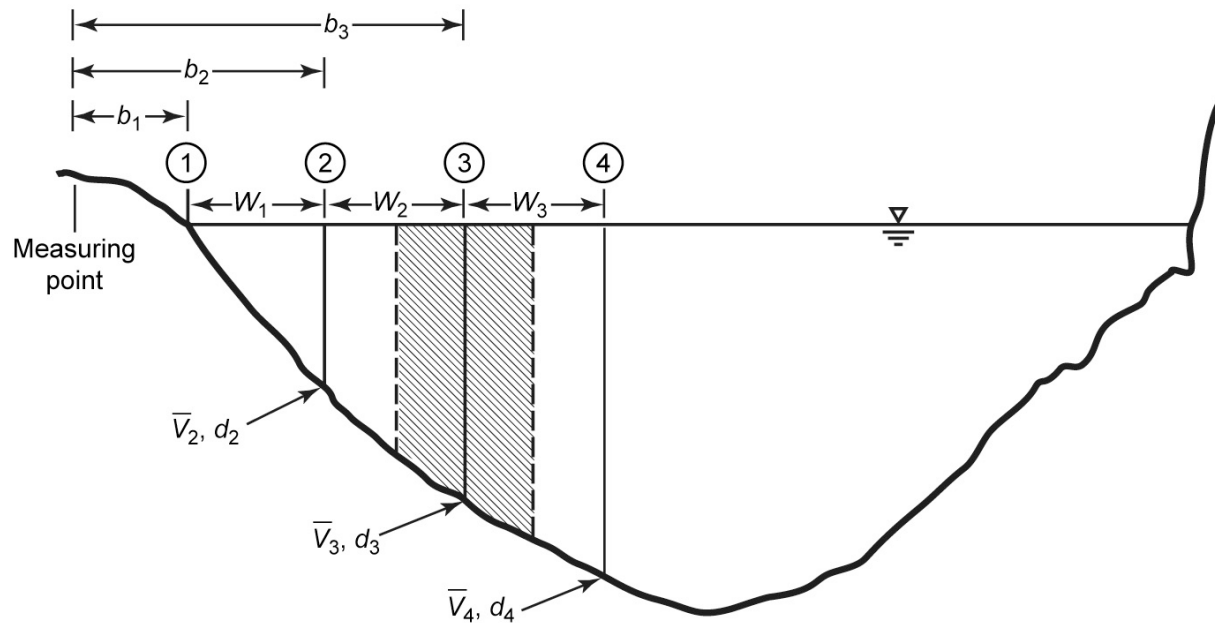

- 1, 2, 3, ... Stations
- b_1, b_2, b_3, \dots Distance from the initial point to the station
(observation verticals)
- d_1, d_2, d_3, \dots Depth of water at the observation verticals
- W_1, W_2, W_3, \dots Width between successive verticals

Discharge Computation by Current Meter – Mean-Section Method

Example 8.8

Figure 8.10 Subsection in the mean-section method.

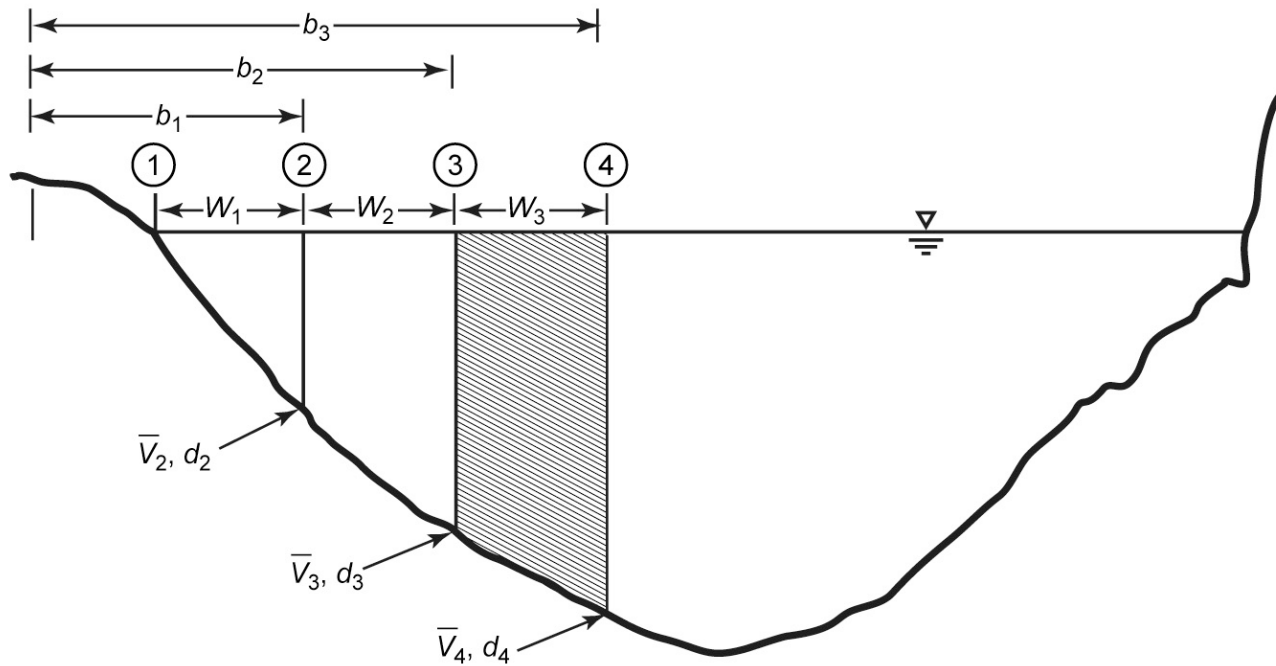

Acoustic Doppler Current Profiler, ADCP

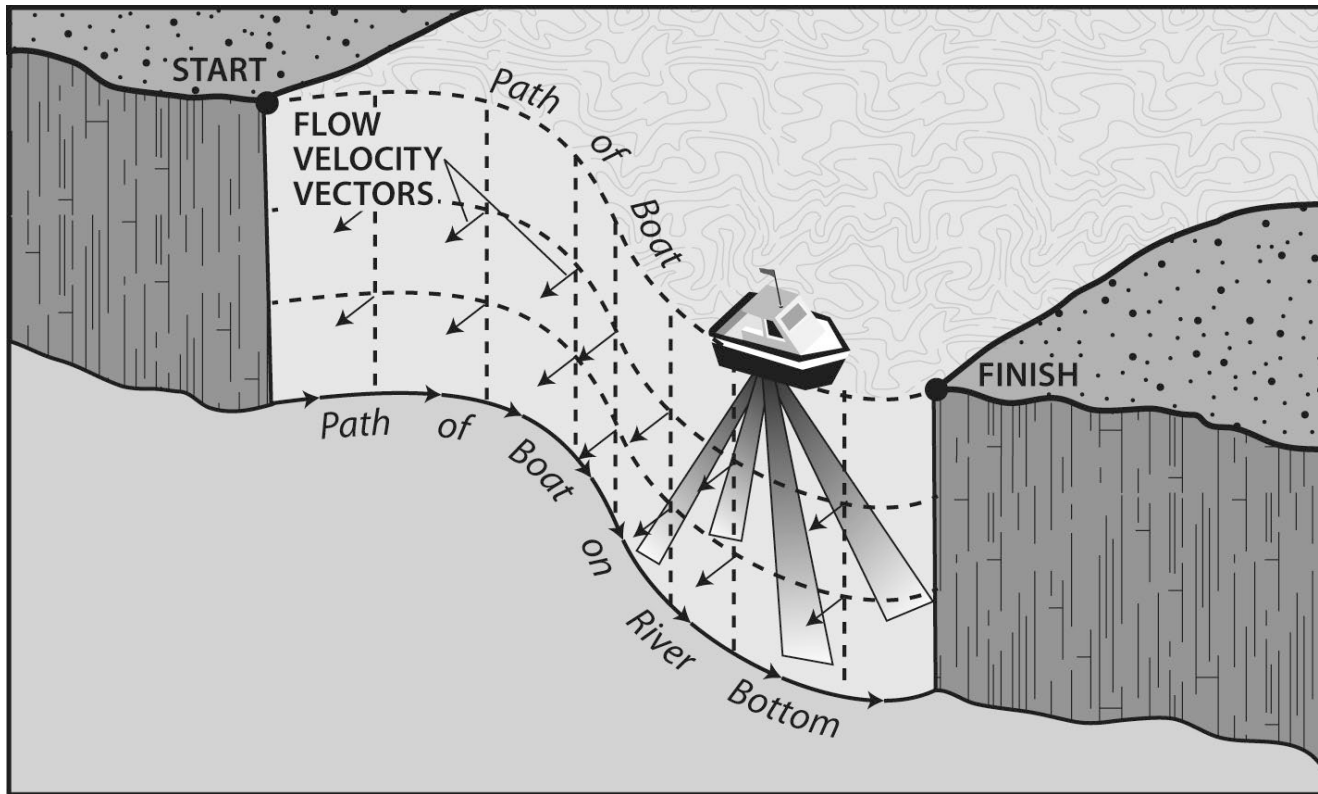

Links to USGS: Streamflow Measurements

- Acoustic

https://www.usgs.gov/centers/sa-water/science/hydroacoustic-applications-technological-advancements-streamgaging-network?qt-science_center_objects=0#qt-science_center_objects

- General

https://www.usgs.gov/special-topic/water-science-school/science/how-streamflow-measured?qt-science_center_objects=0#qt-science_center_objects